

REVISIONS

REV	DESCRIPTION	DRAWN	DATE	APP	DATE
Δ	ENGINEERING RELEASE	DML	1/21/02	-	-

FASTENER LIST

ITEM	DESCRIPTION	MATERIAL	QTY
①	HILTI HSL M 16/25 HEAVY DUTY EXPANSION ANCHOR, W/NUT & WASHER	SS	24
②	3/8 DIA x 1 LONG HEX HEAD BOLT W/NUT & 2-WASHERS	SS	26

BILL OF MATERIALS

ITEM	DESCRIPTION	MATERIAL	QTY
A	SIDE VERTICAL SUPPORT (1/4" x 1")	STL	2
B	MIDDLE VERTICAL SUPPORT (1/4" x 1")	STL	1
C	VERTICAL RETAINING STRAP (1/4" x 1")	STL	2
D	HORIZONTAL RETAINING STRAP (1/4" x 1")	STL	2
E	BLASTSHIELD FABRIC	-	1
F	ANCHORING SUPPORT (1/4" x 1")	STL	6

BLASTSHIELD WRAPPED TWICE AROUND RETAINER

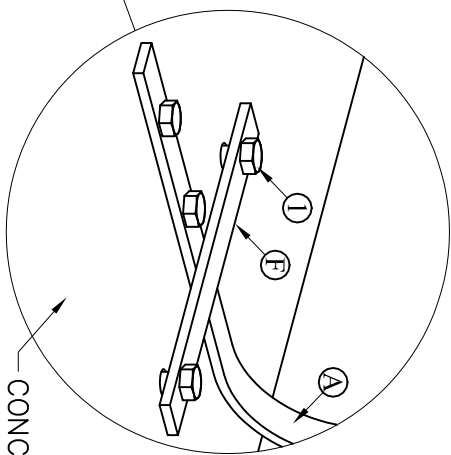
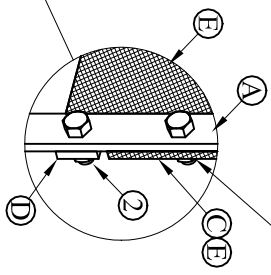

CONCRETE FLOOR

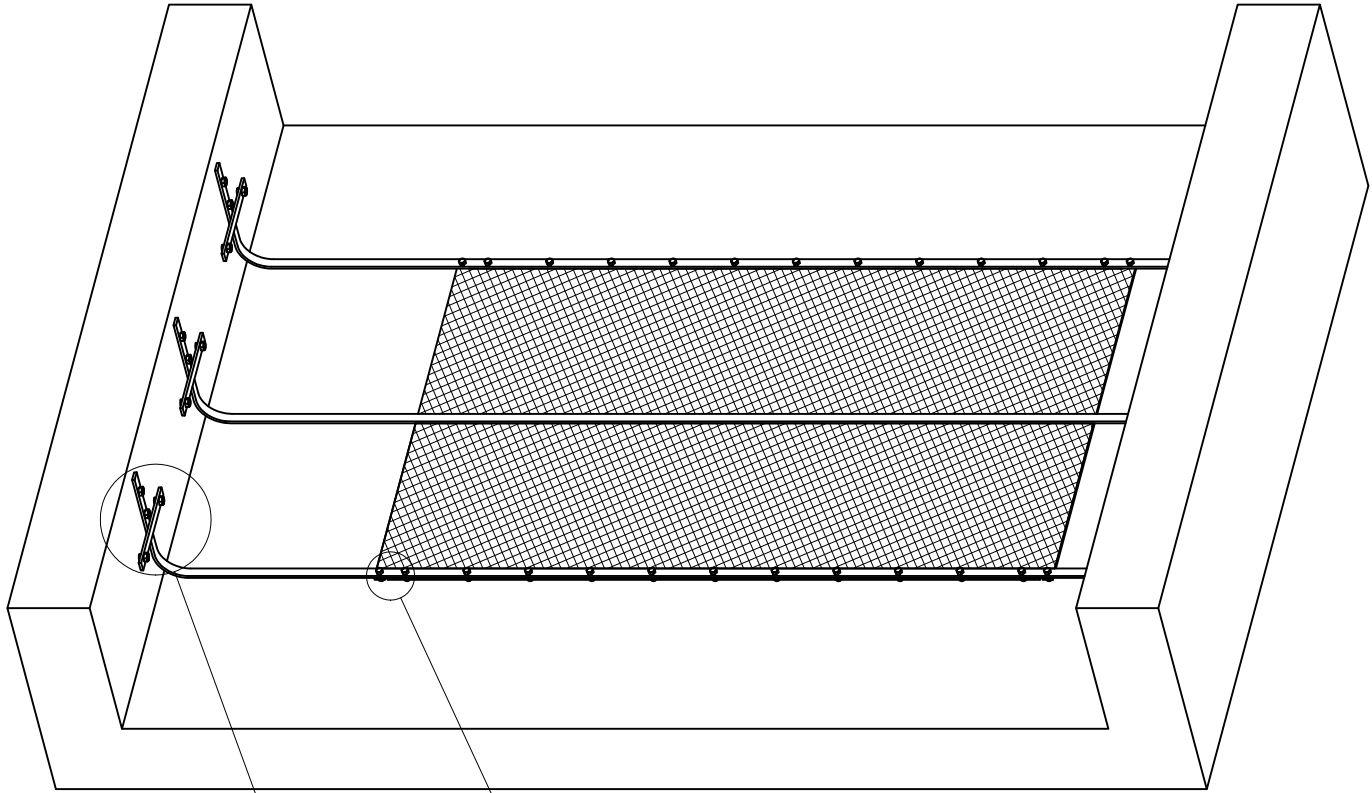

- CAD GENERATED DRAWING. DO NOT MANUALLY UPDATE.
 - UNLESS OTHERWISE SPECIFIED, ALL DIMENSIONS ARE IN INCHES.
 - THE INFORMATION CONTAINED IN THIS DRAWING IS THE SOLE PROPERTY OF PROTECH. ANY REPRODUCTION IN PART OR IN WHOLE WITHOUT THE WRITTEN PERMISSION OF PROTECH IS PROHIBITED.



PROTECH
 An Armor Holdings Company
 138 Hubbard Ave.,
 Pittsfield, Ma., 01240

APPROVALS		DATE	TITLE
DRAWN	DML	1/21/02	BLASTSHIELD MODEL D4
CHECKED	--	--	STANDARD CUSTOMER DWG
QUALITY ENGINEER	--	--	ST-BH-D4

CUSTOMER: STANDARD CUSTOMER
 DWG. NO.: STBHD4C001
 PROJ. NO.: ST-BH-D4
 PAGE SIZE: A SCALE: 1"=1-1/2' SHEET: 1 OF 3 REV: Δ